

ROUND BOTTOM INCLINE CONVEYORS

Head Features:

- Computer aided modular bolt together design
- CNC manufactured
- 3.45-4.20-5.21 mm thickness standard galvanized construction
- Heavy duty pillow block bearings
- Heavy duty drive sprocket
- Removable inspection cover
- Dust seals

Trough Features:

- Computer aided modular bolt together design
- CNC manufactured
- 3.45 mm thickness galvanized sides
- 3.45-4.20-5.21 mm thickness galvanized bottoms available
- UHMW return rollers
- Pre-assembled trunk sections
- Optional abrasion resistant steel liners for bottom and sides

Tail Features:

- Computer aided modular bolt together design
- CNC manufactured
- 3.45-4.20-5.21 mm thickness standard galvanized construction
- Heavy duty pillow block bearings
- Heavy duty sprocket
- Acme screw slack adjusters
- Removable inspection covers
- Dust seals

ROUND BOTTOM INCLINE CONVEYORS



MTPH	MODEL	RPM	MPS
25	GLID-09x14	34	0.376
38	GLID-09x14	54	0.559
53	GLID-09x14	71	0.782
63	GLID-09x14	85	0.94
79	GLID-12x14	69	0.787
86	GLID-12x14	78	0.864
99	GLID-12x14	90	0.991
101	GLID-17x20	29	0.503
126	GLID-17x20	36	0.63
152	GLID-17x20	43	0.757
177	GLID-17x20	50	0.884
177	GLID-24X24	26	0.538
203	GLID-24X24	29	0.615
228	GLID-24X24	33	0.681
253	GLID-24X24	37	0.772

Capacities are based on #2 dry corn.

	9 X 14	12 X 14	17 X 14	17 X 20	24 X 24
Radius	15748	16256	18288	19812	19812
A	2286	3048	4318	4318	6096
B	3556	3556	3556	5080	6096
C	7366	8128	10414	10414	12954
D	6477	7620	8890	10414	
E	4902	5588	6858	8382	
F	18415	19050	18796	20066	
G	5410	5969	7620		
J	5080	5080	5842	7620	
L	9144	9525	9525	11176	
M	65278	65278	66548	69342	
P	7747	8509	10795	10795	
Q	9144	9144	10668	12192	
R	889	889	889	889	
S	9144	9525	9525	11557	

Dimensions (shown in millimeters) are nominal and subject to change.

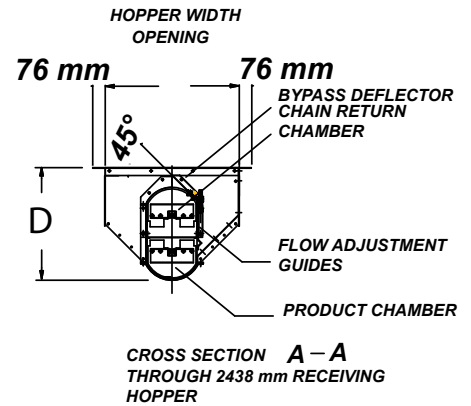
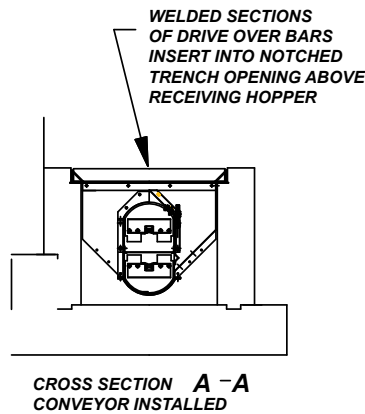
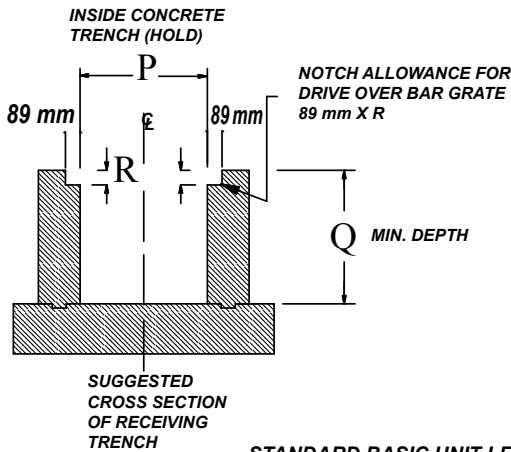

STANDARD BASIC UNIT LENGTH
PLUS OPTIONAL 1524 mm / 3048 mm STRAIGHT LENGTHS

HEAD SECTION
R/H OR L/H
DRIVE OPTIONS

ANGLE OF CURVE CAN BE ADJUSTED IN 5 DEGREE
INCREMENTS UP TO 50 DEGREES

CENTER PAN THROUGH FULL LENGTH OF CONVEYOR
PLUS OPTIONAL 1524 mm / 3048 mm STRAIGHT TROUGH SECTIONS

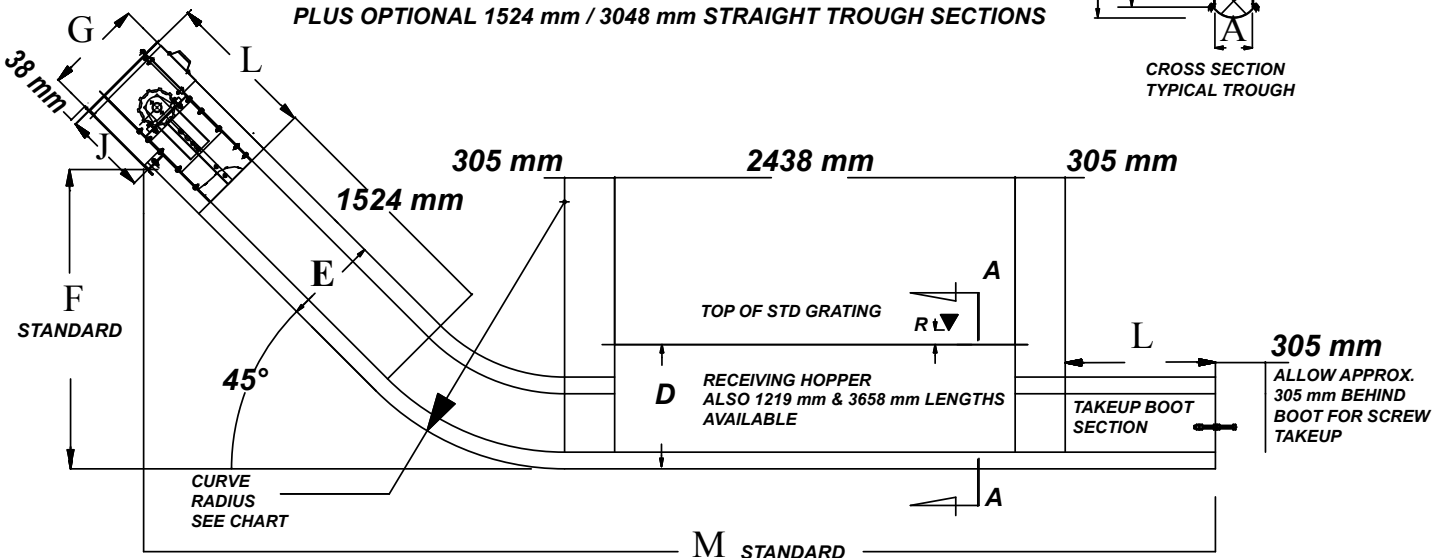
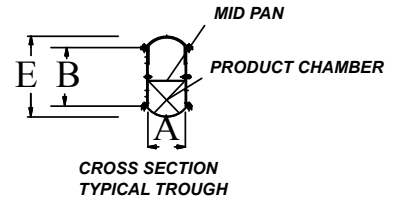

ALL INCLUDED IN BASIC PRICE



Chore-Time Brock International
A Division of CTB, Inc. • Milford, Indiana U.S.A.
Phone: +1.574.658.9323 • Internet: www.ctbworld.com
E-Mail: world@ctbworld.com CTB-1748/0307